

SUHNER[®] PLANAR ANTENNA FOR WIRELESS COMMUNICATION

SPA 2400/80/9/0/DS

Technical Data

Electrical Properties

Frequency range	2300 - 2500 MHz
Impedance	50 Ω
VSWR	1.5
Polarization	dual linear, ± 45° slant
Gain	8.5 dBi
3 dB beamwidth horizontal	80°
3 dB beamwidth vertical	70°
Downtilt	0°
Isolation between ports	30 dB
Front to back ratio	18 dB
Max. power	75 W (CW) at 25°C

Mechanical Properties

Dimensions	101 x 95 x 32 mm (3.98" x 3.74" x 1.26")
Weight	0.11 kg (0.24 lbs.)
Housing material	ASA and aluminium
Radome material	ASA
Radome color	RAL 7035 (light-grey)
Mounting bracket color	RAL 7042 (dark-grey)
Operating temperature range	- 40°C to + 80°C
Storage temperature range	- 40°C to + 80°C
Windload	15 N at 160km/h (100mph)

Available Types

Article no.	Article no.	
1324.19.0017	22659413	SMA female
1324.26.0017	22659722	TNC female

Mounting Hardware

Article no.	Article no.	
9091.99.0029	22649576	mast mounting accessory
9091.99.0080	22652651	mast mounting and side/down-tilt accessory

Wall mounting material included.



Radiation Pattern

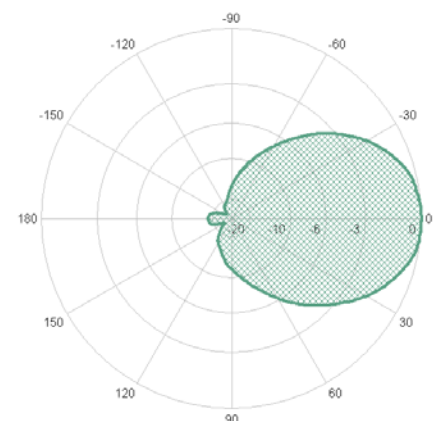

horizontal

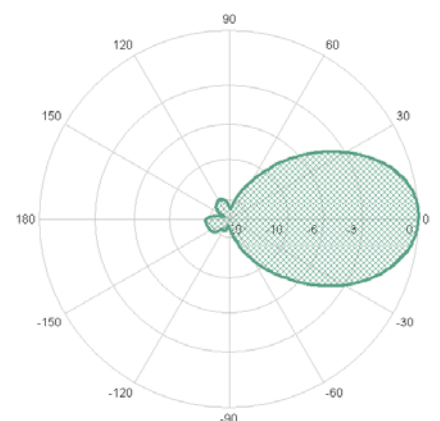

vertical

SUHNER[®] PLANAR ANTENNA FOR WIRELESS COMMUNICATION

SPA 2400/80/9/0/DS

Dimensions (mm)

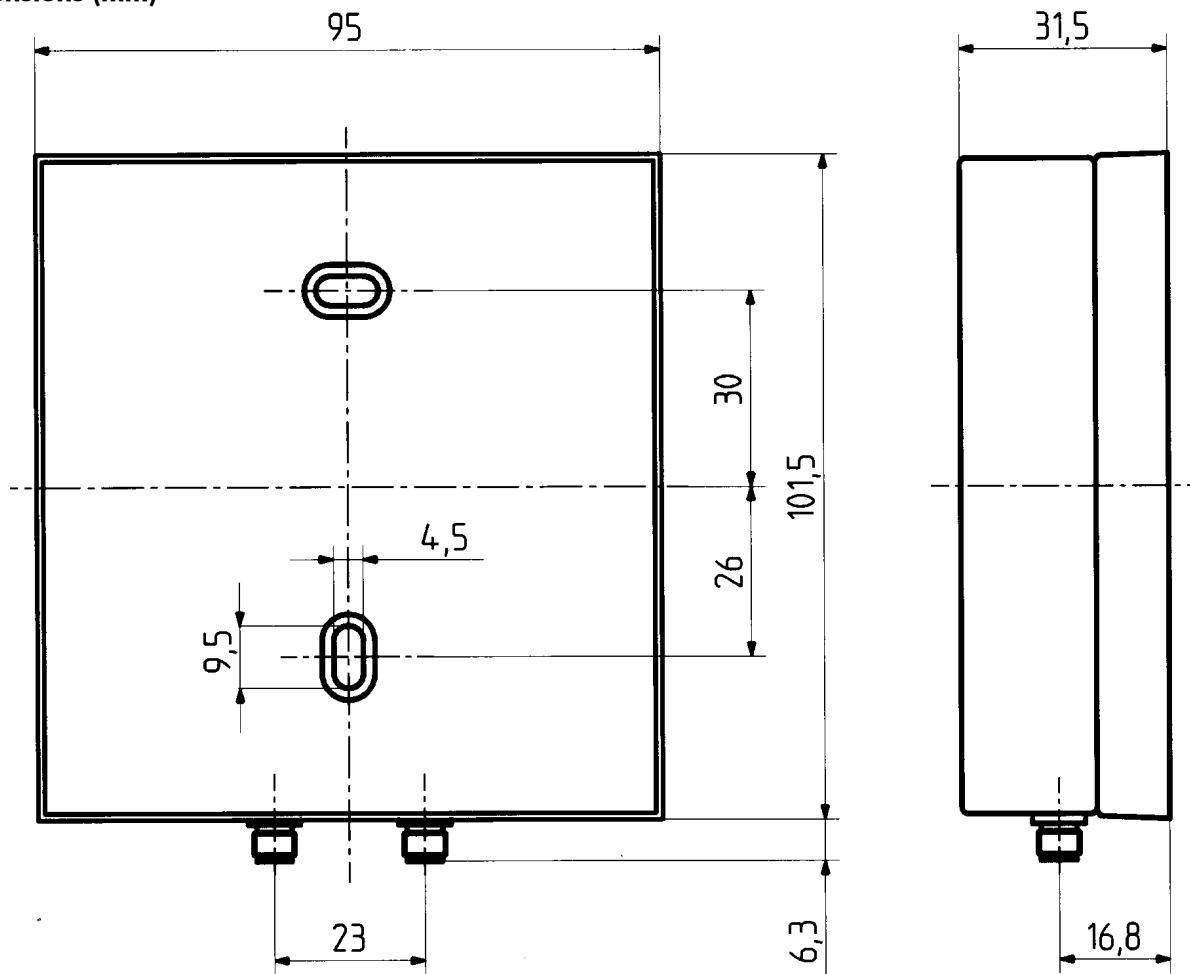

Mounting and security instructions see HUBER+SUHNER document number 01.02.0777.
The document can be ordered at HUBER+SUHNER AG, Switzerland.

HUBER+SUHNER group is certified according to ISO 9001 and ISO 14001.

WAIVER!

While the information contained has been carefully compiled to the best of our present knowledge, it is not intended as representation or warranty of any kind on our part regarding the fitness of the products concerned for any particular use or purpose and neither shall any statement contained herein be construed as a recommendation to infringe any industrial property rights or as a license to use any such rights. The fitness of each product for any particular purpose must be checked beforehand with our specialists.



HUBER+SUHNER AG
Wired Solutions + Networks
Communication + Power Networks
CH-9100 Herisau, Switzerland
Tel.: +41 (0)71 353 41 11
Fax: +41 (0)71 353 47 51
www.hubersuhner.com

Document no.: 01.02.0866
Issue no.: 2
Supersedes: 10.2002

Uncontrolled Copy

Issued/Checked/Released: 4159/4174/10.2002
Last amended: 4159